



## Application of Trackless Digital Technology in the Specialized Strength Training of Para Snowboard Athletes

<sup>1</sup>Xuanzhen Cen

<sup>1</sup> Óbuda University, Doctoral School on Safety and Security Sciences, Hungary  
cenxuanzhen@outlook.com

### Introduction

Para snowboarders need to perform the “pulling door” at the starting stage, to achieve the best initial speed. However, due to the different levels of Para snowboarders, traditional strength training cannot meet the individualized training demands of disabled athletes. And unscientific training patterns may lead to an increased risk of sports injury. Therefore, the purpose of this study was to explore the application effect of the trackless digital training system in the Chinese para snowboard team’s special strength training.

### Methods

A total of eight male para snowboard athletes (4 UL level, 1 LL1 level, and 3 LL2 level) from the Chinese national team participated in this study. A 4-week special training based on the centripetal isotonic mode of the trackless digital training system (Fig. 1.) for starting movement was designed, and related test indicators of special strength quality included peak/average power and peak/average speed in the centripetal phase of the “pulling door” movement. The paired-sample t-test was used for statistical analysis of each index before and after training.

### Results

After 4 weeks of training through the trackless digital training system, the peak speed and average power of the eight athletes’ start movements were significantly increased compared to before training ( $P < 0.05$ ). Among them, the average speed of 6 athletes (including 4 UL level, 1 LL1 level, and 1 LL2 level) increased significantly compared with before training ( $P < 0.05$ ), and the peak power of 5 athletes (including 4 UL level and 1 LL1 level) increased significantly compared with before training ( $P < 0.05$ ).

### Conclusion

The trackless digital training system can significantly improve the specific strength index of the elite para snowboarders during the “pulling door” movement, thereby improving their performance in the starting stage. At the same time, the secondary-developed training system can meet the personalized training needs and digital load monitoring of different disability levels of disabled athletes, meanwhile, it can effectively reduce the risk of sports injury caused by training.

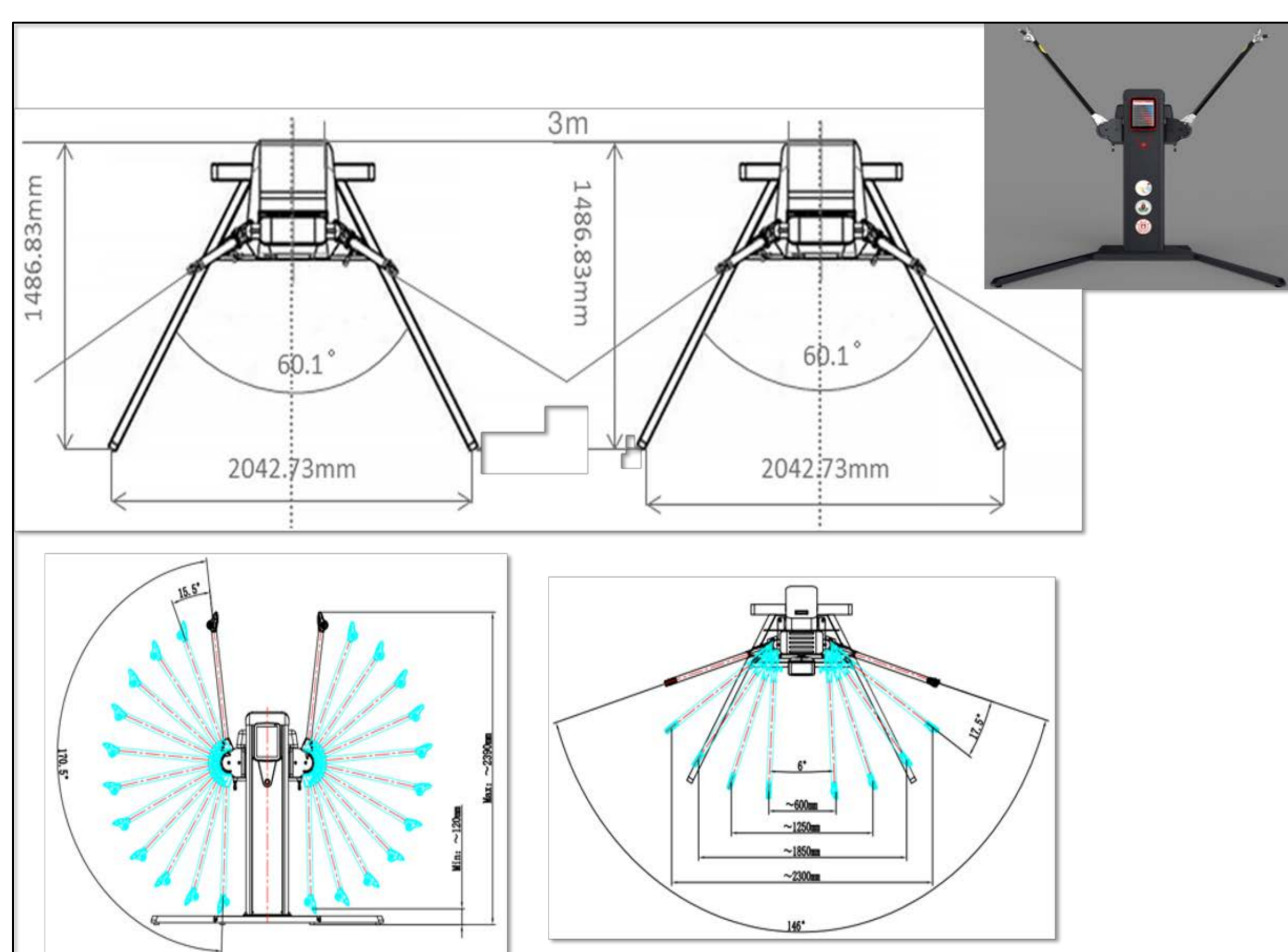

Fig. 1. The Trackless Digital Training System



### Acknowledgement

We acknowledge the financial support of this work by the National Key R&D Program of China (2018YFF0300905)